



THE COUNCIL OF COMMUNITY COLLEGES OF JAMAICA

ASSOCIATE OF SCIENCE EXAMINATION

SEMESTER I – 2018 DECEMBER

PROGRAMME: ARCHITECTURE AND CONSTRUCTION TECHNOLOGY
COURSE NAME: GENERAL TECHNOLOGY
CODE: GTEC1101
YEAR GROUP: ONE
DATE: MONDAY, 2018 DECEMBER 10
TIME: 12:00 NOON – 2:00 P.M.
DURATION: 2 HOURS
EXAMINATION TYPE: FINAL

This Examination paper has 8 pages

INSTRUCTIONS:

1. ANSWER ALL QUESTIONS FROM SECTION A
2. SECTION B CONSISTS OF FOUR (4) QUESTIONS. ANSWER ANY TWO (2)

DO NOT TURN THIS PAGE UNTIL YOU ARE TOLD TO DO SO

SECTION B

Instruction: In the booklet provided, answer any **TWO (2)** questions from this section.

Question 1

- A. State **FIVE (5)** safe work practices one should adhere to when using a drill press. **(5 marks)**
- B. List **FIVE (5)** observations that should be followed when drilling a hole. **(5 marks)**
- C. Differentiate between countersinks and counterbores. **(6 marks)**
- D. Label the drill press below:

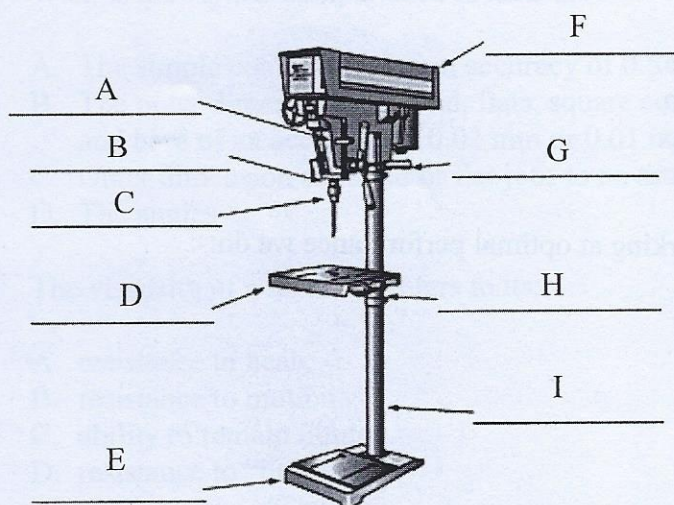
**(9 marks)**

- E. State **FIVE (5)** operations that can be performed on a lathe. **(5 marks)**

(Total 30 marks)

Question 2

- A. Explain **FIVE (5)** classifications of fire. (10 marks)
- B. What is meant by the term Fire Load? (4 marks)
- C. When and how should a fire extinguisher be used? (6 marks)
- D. Convert:
i. 40 Sqm to SqIn
ii. 4330mm to FtIn (6 marks)
- E. How many 24"x 24" Tiles would be needed for a 53 Sqm house? (4 marks)
- (Total 30 marks)**

Question 3

- A. List **FIVE (5)** general safety rules that should be adhered to in the workshop. (5 marks)
- B. While operating the table saw, a colleague of yours received minor cuts on his hand. Outline the appropriate steps you would take while administering first aid treatment. (6 marks)
- C. While working on a construction site, you are exposed to hazards of various forms. Describe **TWO (2)** hazards that could affect any **TWO (2)** body part that one would be exposed to and how the hazard may be eliminated/controlled. Copy and complete the table below with your response.

Body Part	Hazard	Elimination/Control	PPE

(10 marks)

- D. Explain **THREE (3)** factors that contribute to a comfortable working environment. (9 marks)
- (Total 30 marks)**

Question 4

- A. Define the following terms as it relates to fire:
- i. fire triangle
 - ii. fire spread
 - iii. fire stopping
- (6 marks)
- B. Differentiate between low, medium and high fire load. (6 marks)
- C. With the aid of a diagram explain how to protect wood as a structural element. (8 marks)
- D. Explain the purpose of fire escape route for buildings. (3 marks)
- E. With the aid of a diagram, show escape routes for a small commercial. (7 marks)

(Total 30 marks)

END OF EXAMINATION